

Lecture 6: Project Time Management

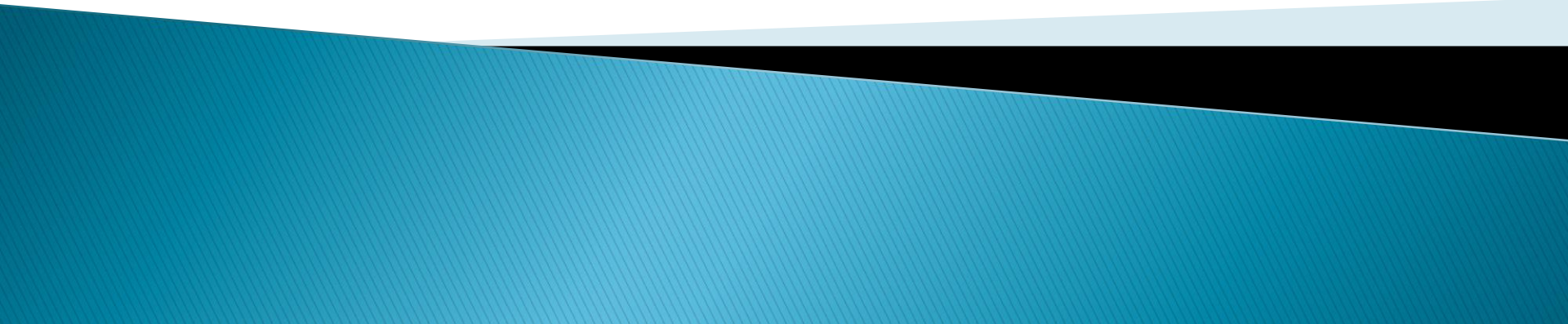

Learning Objectives

- ▶ Understand the importance of project schedules and good project time management
- ▶ Discuss the process of planning schedule management
- ▶ Define activities as the basis for developing project schedules
- ▶ Describe how project managers use network diagrams and dependencies to assist in activity sequencing
- ▶ Understand the relationship between estimating resources and project schedules
- ▶ Explain how various tools and techniques help project managers perform activity duration estimates

Learning Objectives

- ▶ Use a Gantt chart for planning and tracking schedule information, find the critical path for a project, and describe how critical chain scheduling and the Program Evaluation and Review Technique (PERT) affect schedule development
- ▶ Understand how time management is addressed using Agile
- ▶ Discuss how reality checks and discipline are involved in controlling and managing changes to the project schedule
- ▶ Describe how project management software can assist in project time management and review words of caution before using this software

Importance of Project Schedules

- ▶ Managers often cite delivering projects on time as one of their biggest challenges
- ▶ Time has the least amount of flexibility; it passes no matter what happens on a project
- ▶ Schedule issues are the main reason for conflicts on projects, especially during the second half of projects

Individual Work Styles and Cultural Differences Cause Schedule Conflicts

- ▶ One dimension of the Meyers-Briggs Type Indicator focuses on peoples' attitudes toward structure and deadline
- ▶ Some people prefer to follow schedules and meet deadlines while others do not (J vs. P)
- ▶ Different cultures and even entire countries have different attitudes about schedules

Media Snapshot

- In contrast to the 2002 Salt Lake City Winter Olympic Games, planning and scheduling was very different for the 2004 Athens Summer Olympic Games and the 2014 Sochi Winter Olympic Games
- Many articles were written before the opening ceremonies in Athens predicting that the facilities would not be ready in time. ...the Greeks even made fun of critics by having construction workers pretend to still be working as the ceremonies began...but the games cost more than twice the planned budget
- The 2014 Winter Olympic Games in Sochi, Russia, suffered even greater financial loss and were the most expensive games in history

Project Time Management Processes

- ▶ **Planning schedule management:** determining the policies, procedures, and documentation that will be used for planning, executing, and controlling the project schedule
- ▶ **Defining activities:** identifying the specific activities that the project team members and stakeholders must perform to produce the project deliverables
- ▶ **Sequencing activities:** identifying and documenting the relationships between project activities
- ▶ **Estimating activity resources:** estimating how many **resources** a project team should use to perform project activities
- ▶ **Estimating activity durations:** estimating the number of work periods that are needed to complete individual activities
- ▶ **Developing the schedule:** analyzing activity sequences, activity resource estimates, and activity duration estimates to create the project schedule
- ▶ **Controlling the schedule:** controlling and managing changes to the project schedule

Project Time Management Summary

Planning

Process: **Plan schedule management**

Outputs: Schedule management plan

Process: **Define activities**

Outputs: Activity list, activity attributes, milestone list, project management plan updates

Process: **Sequence activities**

Outputs: Project schedule network diagrams, project documents updates

Process: **Estimate activity resources**

Outputs: Activity resource requirements, resource breakdown structure, project documents updates

Process: **Estimate activity durations**

Outputs: Activity duration estimates, project documents updates

Process: **Develop schedule**

Outputs: Schedule baseline, project schedule, schedule data, project calendars, project management plan updates, project documents updates



Monitoring and Controlling

Process: **Control schedule**

Outputs: Work performance information, schedule forecasts, change requests, project management plan updates, project documents updates, organizational process assets updates

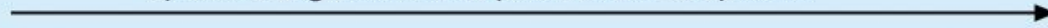

Project Start

Project Finish



Planning Schedule Management

- ▶ The project team uses expert judgment, analytical techniques, and meetings to develop the schedule management plan
- ▶ A schedule management plan includes:
 - Project schedule model development
 - The scheduling methodology
 - Level of accuracy and units of measure
 - Control thresholds
 - Rules of performance measurement
 - Reporting formats
 - Process descriptions

Defining Activities

- ▶ An **activity** or **task** is an element of work normally found on the work breakdown structure (WBS) that has an expected duration, a cost, and resource requirements
- ▶ Activity definition involves developing a more detailed WBS and supporting explanations to understand **all** the work to be done so you can develop realistic cost and duration estimates

Activity Lists and Attributes

- ▶ An **activity list** is a tabulation of activities to be included on a project schedule that includes
 - the activity name
 - an activity identifier or number
 - a brief description of the activity
- ▶ **Activity attributes** provide more information such as predecessors, successors, logical relationships, leads and lags, resource requirements, constraints, imposed dates, and assumptions related to the activity

Milestones

- ▶ A **milestone** is a significant event that normally has no duration
- ▶ It often takes several activities and a lot of work to complete a milestone
- ▶ They're useful tools for setting schedule goals and monitoring progress
- ▶ Examples include obtaining customer sign-off on key documents or completion of specific products

What Went Wrong?

- ▶ At the U.S. Federal Bureau of Investigation (FBI), poor time management was one of the reasons behind the failure of Trilogy, a “disastrous, unbelievably expensive piece of vaporware, which was more than four years in the (un)making. The system was supposed to enable FBI agents to integrate intelligence from isolated information silos within the Bureau.”*
- ▶ In May 2006, the Government Accounting Agency said that the Trilogy project failed at its core mission of improving the FBI’s investigative abilities and was plagued with missed milestones and escalating costs. Sentinel replaced Trilogy in 2007.
- ▶ During a test exercise in 2011, Sentinel experienced two outages, and the FBI determined that the current hardware structure was inadequate. In 2014, the system still wasn’t working well.

*Roberts, Paul, “Frustrated contractor sentenced for hacking FBI to speed deployment,” *InfoWorld Tech Watch*, (July 6, 2006).

Sequencing Activities

- ▶ Involves reviewing activities and determining dependencies
- ▶ A **dependency** or **relationship** is the sequencing of project activities or tasks
- ▶ You *must* determine dependencies in order to use critical path analysis

Three types of Dependencies

- ▶ **Mandatory dependencies:** inherent in the nature of the work being performed on a project, sometimes referred to as hard logic
- ▶ **Discretionary dependencies:** defined by the project team., sometimes referred to as soft logic and should be used with care since they may limit later scheduling options
- ▶ **External dependencies:** involve relationships between project and non-project activities

Network Diagrams

- ▶ Network diagrams are the preferred technique for showing activity sequencing
- ▶ A **network diagram** is a schematic display of the logical relationships among, or sequencing of, project activities
- ▶ Two main formats are the arrow and precedence diagramming methods

Network Diagram for Project X

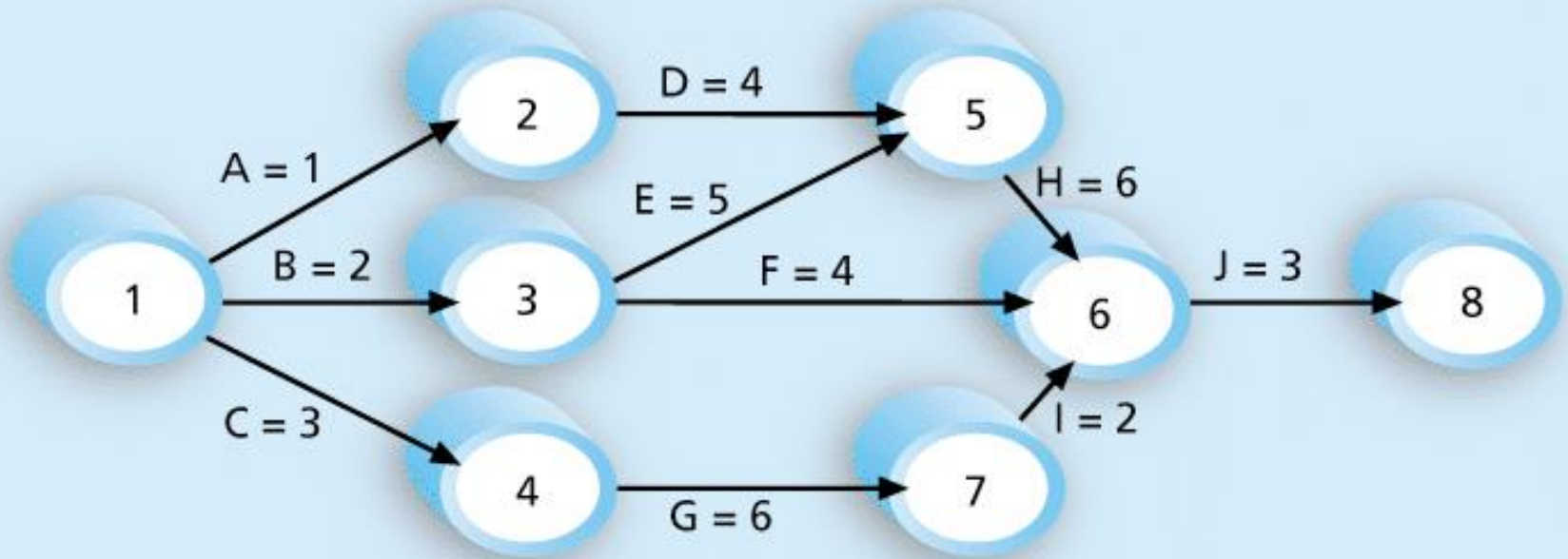

Note: Assume all durations are in days; A=1 means Activity A has a duration of 1 day.

Arrow Diagramming Method (ADM)

- ▶ Also called activity-on-arrow (AOA) network diagrams
- ▶ Activities are represented by arrows
- ▶ Nodes or circles are the starting and ending points of activities
- ▶ Can only show finish-to-start dependencies

Process for Creating AOA Diagrams

1. Find all of the activities that start at node 1. Draw their finish nodes and draw arrows between node 1 and those finish nodes. Put the activity letter or name and duration estimate on the associated arrow
2. Continuing drawing the network diagram, working from left to right. Look for bursts and merges. **Bursts** occur when a single node is followed by two or more activities. A **merge** occurs when two or more nodes precede a single node
3. Continue drawing the project network diagram until all activities are included on the diagram that have dependencies
4. As a rule of thumb, all arrowheads should face toward the right, and no arrows should cross on an AOA network diagram



Precedence Diagramming Method (PDM)

- ▶ Activities are represented by boxes
- ▶ Arrows show relationships between activities
- ▶ More popular than ADM method and used by project management software
- ▶ Better at showing different types of dependencies

Task Dependency Types

Task dependencies

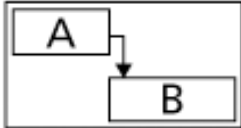
The nature of the relationship between two linked tasks. You link tasks by defining a dependency between their finish and start dates. For example, the "Contact caterers" task must finish before the start of the "Determine menus" task. There are four kinds of task dependencies in Microsoft Project.

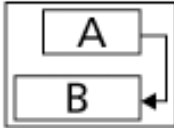
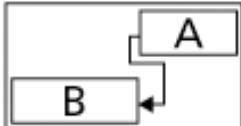
Task dependency	Example	Description
Finish-to-start (FS)		Task (B) cannot start until task (A) finishes.
Start-to-start (SS)		Task (B) cannot start until task (A) starts.
Finish-to-finish (FF)		Task (B) cannot finish until task (A) finishes.
Start-to-finish (SF)		Task (B) cannot finish until task (A) starts.

Sample PDM Network Diagram

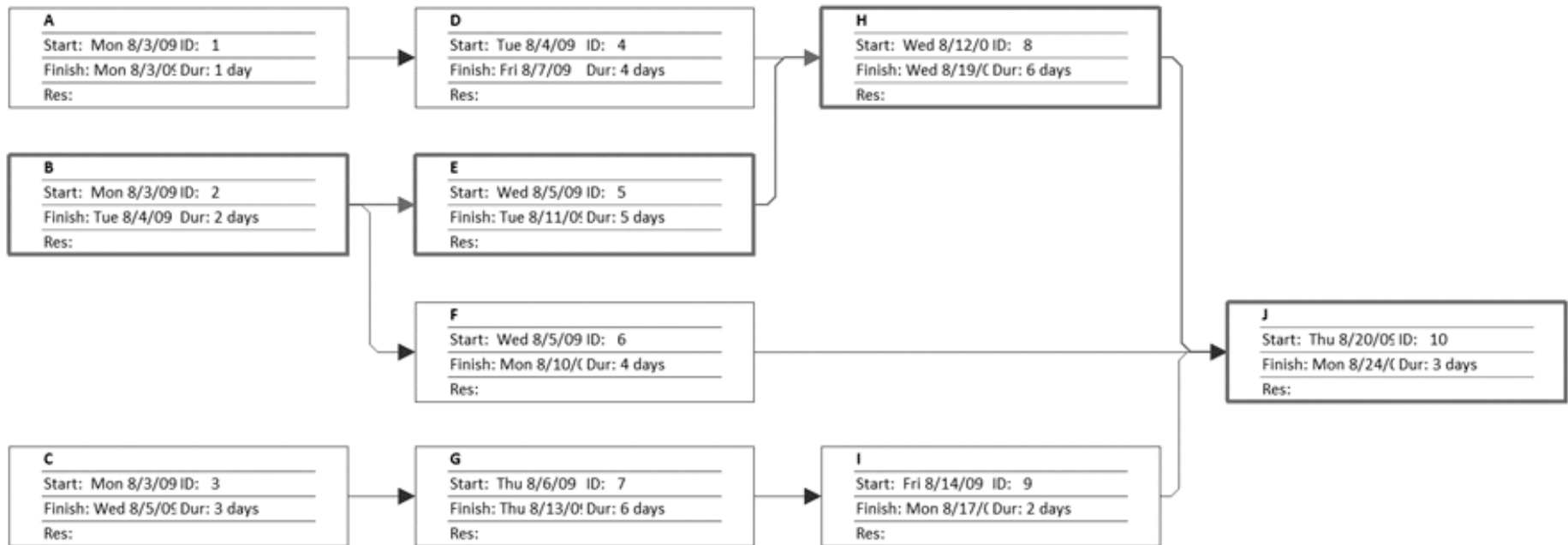

Estimating Activity Resources

- ▶ Before estimating activity durations, you must have a good idea of the quantity and type of resources that will be assigned to each activity; **resources** are people, equipment, and materials
- ▶ Consider important issues in estimating resources
 - How difficult will it be to do specific activities on this project?
 - What is the organization's history in doing similar activities?
 - Are the required resources available?
- ▶ A **resource breakdown structure** is a hierarchical structure that identifies the project's resources by category and type

Activity Duration Estimating

- ▶ **Duration** includes the actual amount of time worked on an activity *plus* elapsed time
- ▶ **Effort** is the number of workdays or work hours required to complete a task
- ▶ Effort does not normally equal duration
- ▶ People doing the work should help create estimates, and an expert should review them

Three-Point Estimates

- ▶ Instead of providing activity estimates as a discrete number, such as four weeks, it's often helpful to create a **three-point estimate**
 - an estimate that includes an optimistic, most likely, and pessimistic estimate, such as three weeks for the optimistic, four weeks for the most likely, and five weeks for the pessimistic estimate
- ▶ Three-point estimates are needed for PERT and Monte Carlo simulations

Developing the Schedule

- ▶ Uses results of the other time management processes to determine the start and end date of the project
- ▶ Ultimate goal is to create a realistic project schedule that provides a basis for monitoring project progress for the time dimension of the project
- ▶ Important tools and techniques include Gantt charts, critical path analysis, and critical chain scheduling, and PERT analysis

Gantt Charts

- ▶ **Gantt charts** provide a standard format for displaying project schedule information by listing project activities and their corresponding start and finish dates in a calendar format
- ▶ **Symbols include:**
 - A black diamond: a milestones
 - Thick black bars: summary tasks
 - Lighter horizontal bars: durations of tasks
 - Arrows: dependencies between tasks

Gantt Chart for Project X

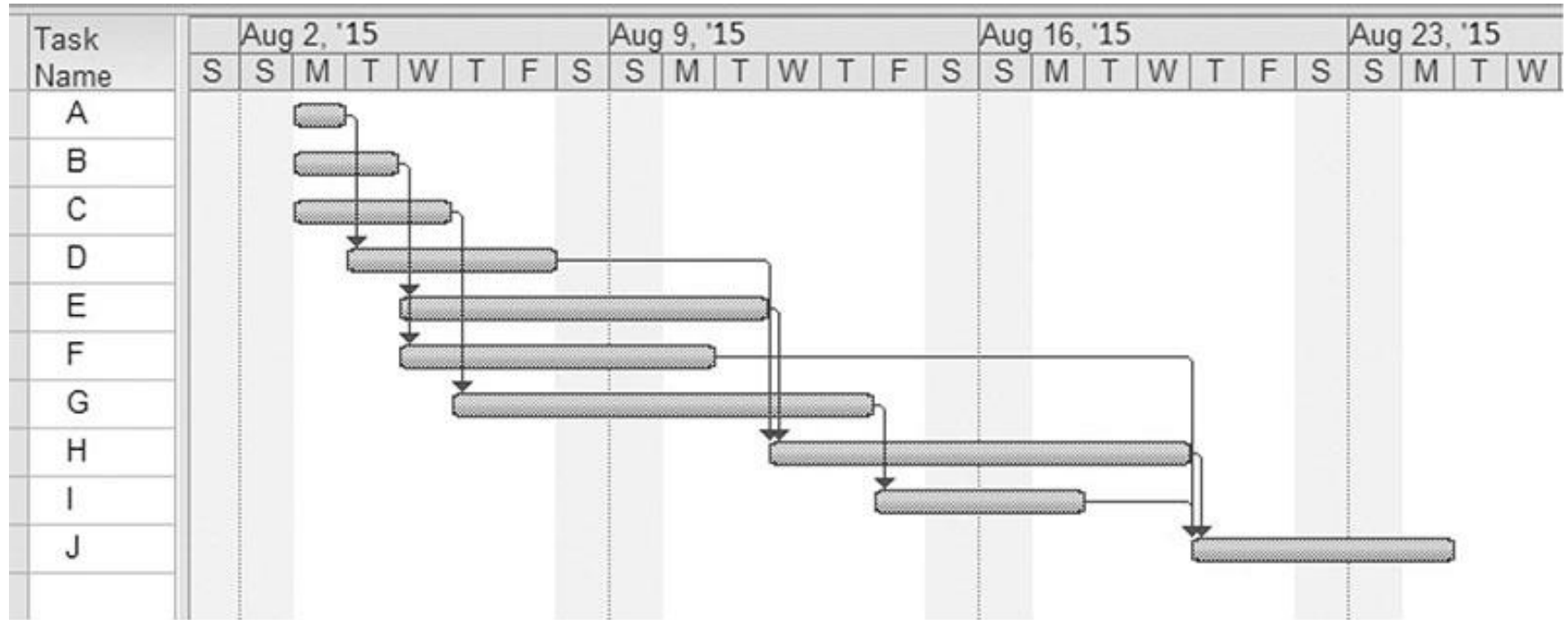

Used with permission from Microsoft Corporation

Gantt Chart for Software Launch Project

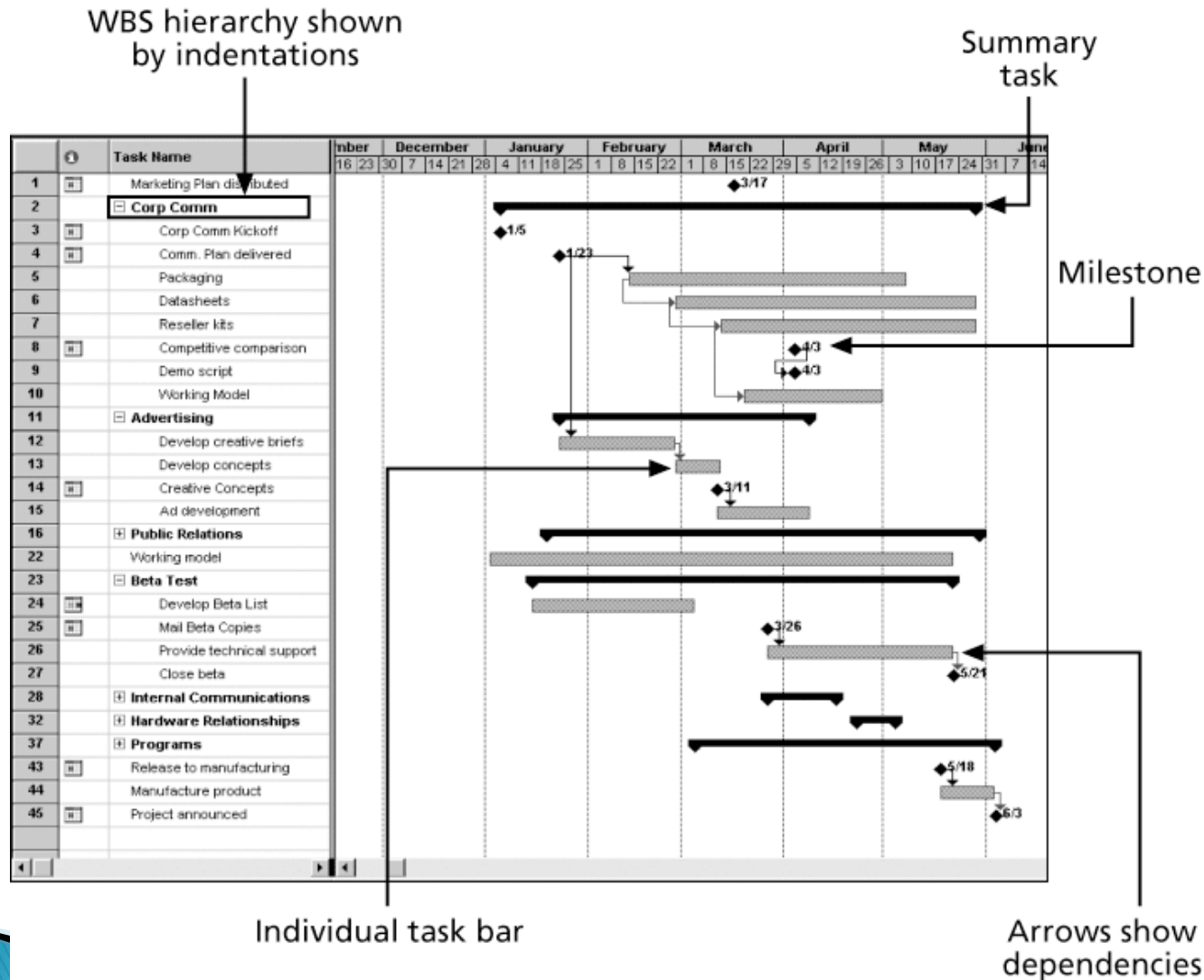

Adding Milestones to Gantt Charts

- ▶ Many people like to focus on meeting milestones, especially for large projects
- ▶ Milestones emphasize important events or accomplishments on projects
- ▶ Normally create milestone by entering tasks with a zero duration, or you can mark any task as a milestone

SMART Criteria

- ▶ Milestones should be
 - **S**pecific
 - **M**easurable
 - **A**ssignable
 - **R**ealistic
 - **T**ime-framed

Best Practice

- ▶ Shawn Achor suggests the 20-second rule in his book, *The Happiness Advantage*
- ▶ People prefer the path of least resistance. For example, if you have to wait in line 20 seconds to get a second scoop of ice cream, you might resist it
- ▶ Achor recommends making it more difficult for yourself to be distracted at work by keeping email or websites closed while you are working
- ▶ Save time by adding time to the distracting behaviors at work

Sample Tracking Gantt Chart

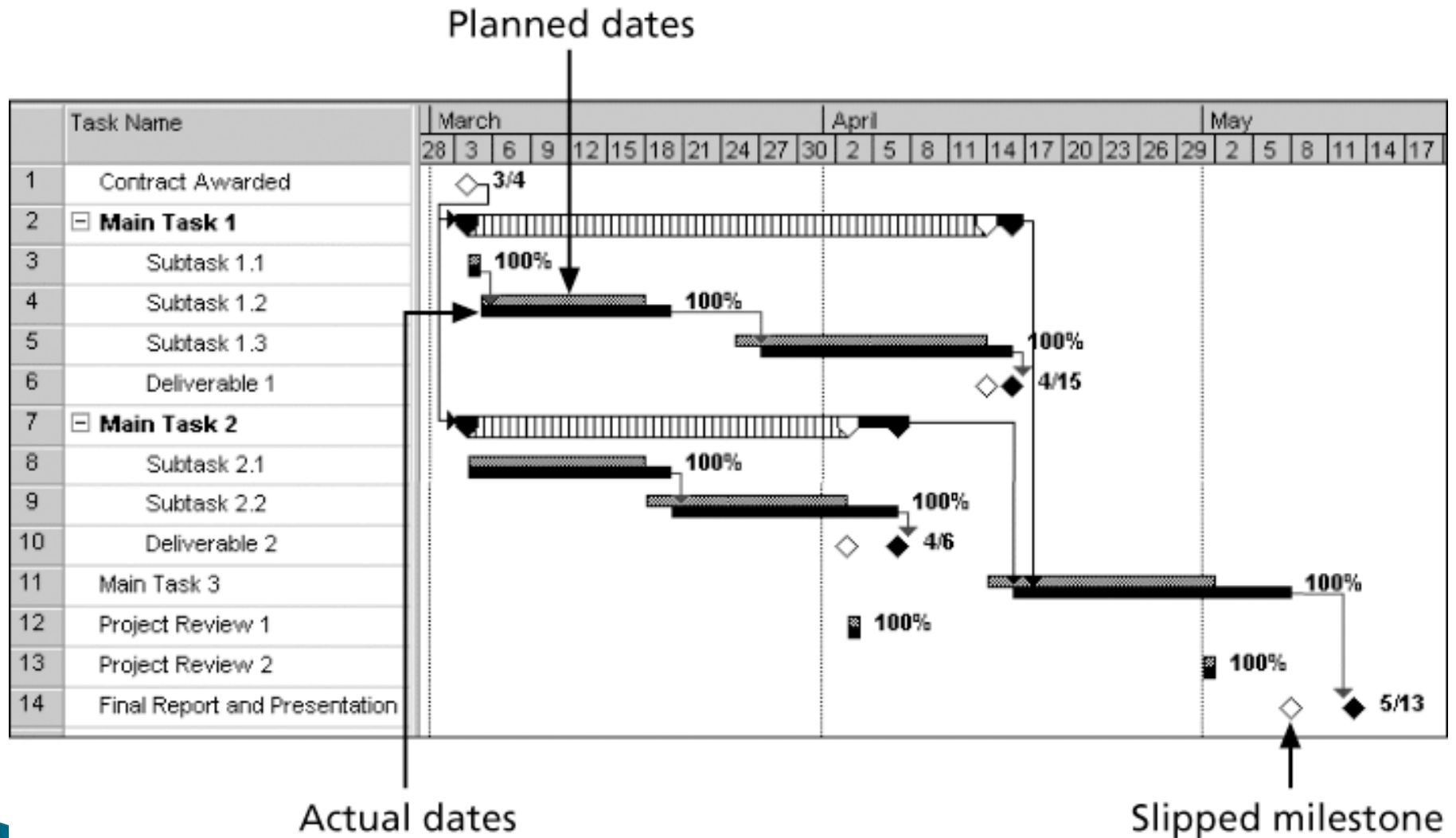

Critical Path Method (CPM)

- ▶ **CPM** is a network diagramming technique used to predict total project duration
- ▶ A **critical path** for a project is the series of activities that determines the *earliest time* by which the project can be completed
- ▶ The critical path is the *longest path* through the network diagram and has the least amount of slack or float
- ▶ **Slack** or **float** is the amount of time an activity may be delayed without delaying a succeeding activity or the project finish date

Calculating the Critical Path

- ▶ First develop a good network diagram
- ▶ Add the duration estimates for all activities on each path through the network diagram
- ▶ The longest path is the critical path
- ▶ If one or more of the activities on the critical path takes longer than planned, the whole project schedule will slip *unless* the project manager takes corrective action

Determining the Critical Path for Project X

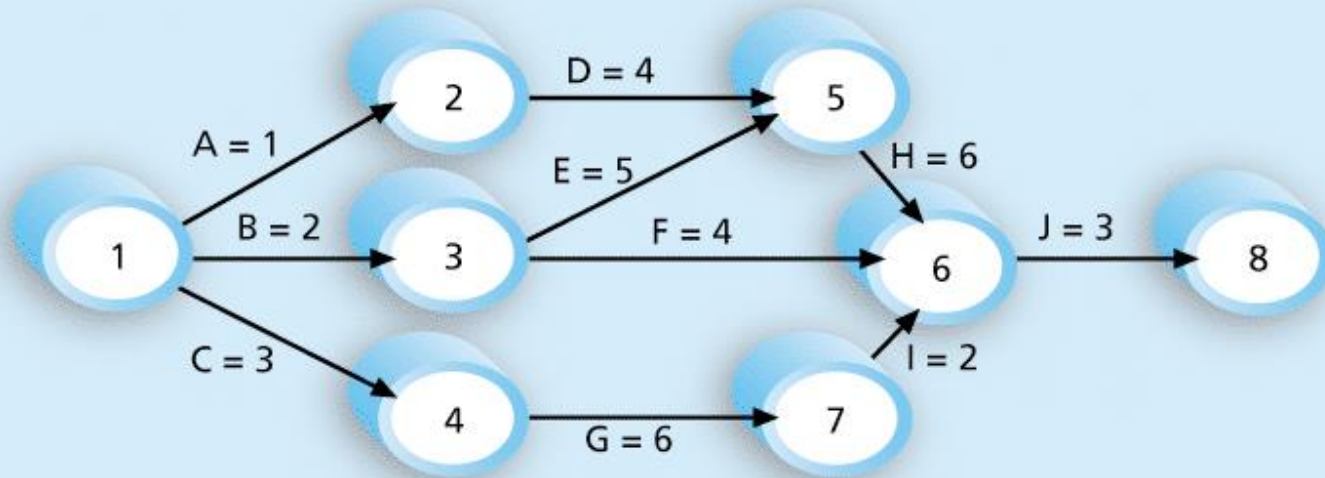

Note: Assume all durations are in days.

Path 1:	A-D-H-J	Length = 1+4+6+3 = 14 days
Path 2:	B-E-H-J	Length = 2+5+6+3 = 16 days
Path 3:	B-F-J	Length = 2+4+3 = 9 days
Path 4:	C-G-I-J	Length = 3+6+2+3 = 14 days

Since the critical path is the longest path through the network diagram, Path 2, B-E-H-J, is the critical path for Project X.

More on the Critical Path

- ▶ A project team at Apple computer put a stuffed gorilla on the top of the cubicle of the person currently managing critical task
- ▶ The critical path is *not* the one with all the critical activities; it only accounts for time
 - Remember the example of **growing grass** being on the critical path for Disney's Animal Kingdom
- ▶ There can be more than one critical path if the lengths of two or more paths are the same
- ▶ The critical path can change as the project progresses

Using Critical Path Analysis to Make Schedule Trade-offs

- ▶ **Free slack** or **free float** is the amount of time an activity can be delayed without delaying the early start of any immediately following activities
- ▶ **Total slack** or **total float** is the amount of time an activity may be delayed from its early start without delaying the planned project finish date
- ▶ A **forward pass** through the network diagram determines the early start and finish dates
- ▶ A **backward pass** determines the late start and finish dates

Calculating Early and Late Start and Finish Dates

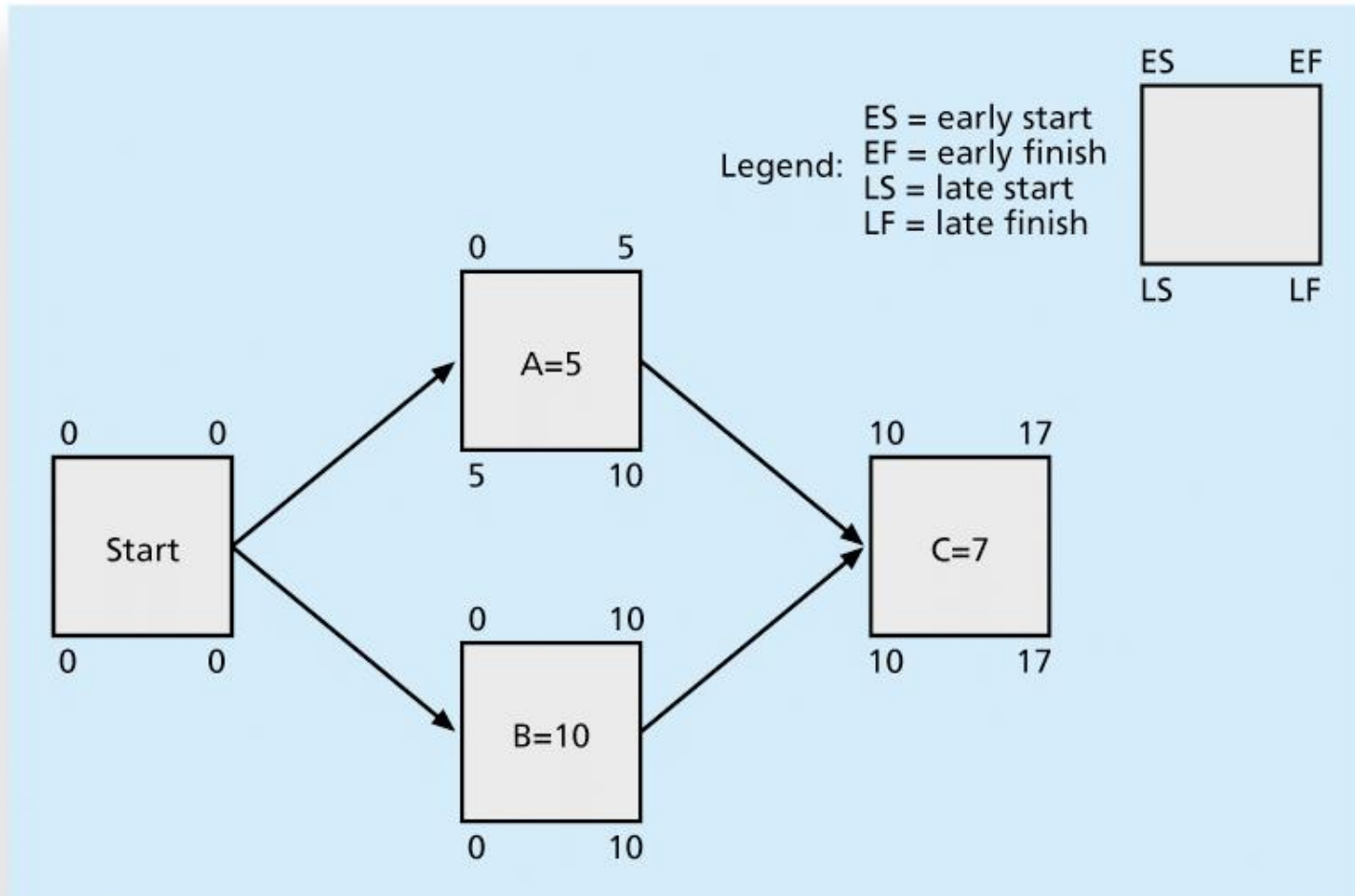

Free and Total Float or Slack for Project X

Task Name	Start	Finish	Late Start	Late Finish	Free Slack	Total Slack
A	8/3/15	8/3/15	8/5/15	8/5/15	0d	2d
B	8/3/15	8/4/15	8/3/15	8/4/15	0d	0d
C	8/3/15	8/5/15	8/5/15	8/7/15	0d	2d
D	8/4/15	8/7/15	8/6/15	8/11/15	2d	2d
E	8/5/15	8/11/15	8/5/15	8/11/15	0d	0d
F	8/5/15	8/10/15	8/14/15	8/17/15	7d	7d
G	8/6/15	8/13/15	8/10/15	8/17/15	0d	2d
H	8/12/15	8/19/15	8/12/15	8/19/15	0d	0d
I	8/14/15	8/17/15	8/18/15	8/19/15	2d	2d
J	8/20/15	8/24/15	8/20/15	8/24/15	0d	0d

© Cengage Learning 2016

Using the Critical Path to Shorten a Project Schedule

- ▶ Three main techniques for shortening schedules
 - Shortening durations of critical activities/tasks by adding more resources or changing their scope
 - **Crashing** activities by obtaining the greatest amount of schedule compression for the least incremental cost
 - **Fast tracking** activities by doing them in parallel or overlapping them

Importance of Updating Critical Path Data

- ▶ It is important to update project schedule information to meet time goals for a project
- ▶ The critical path may change as you enter actual start and finish dates
- ▶ If you know the project completion date will slip, negotiate with the project sponsor

Critical Chain Scheduling

▶ **Critical chain scheduling**

- a method of scheduling that considers limited resources when creating a project schedule and includes buffers to protect the project completion date

▶ **Uses the Theory of Constraints (TOC)**

- a management philosophy developed by Eliyahu M. Goldratt and introduced in his book *The Goal*.

▶ **Attempts to minimize multitasking**

- when a resource works on more than one task at a time

Multitasking Example

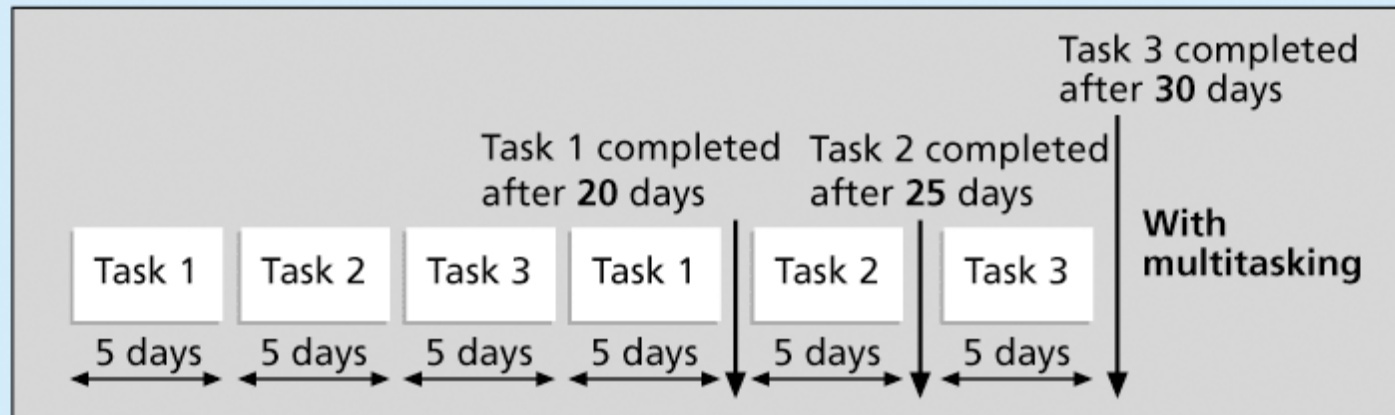
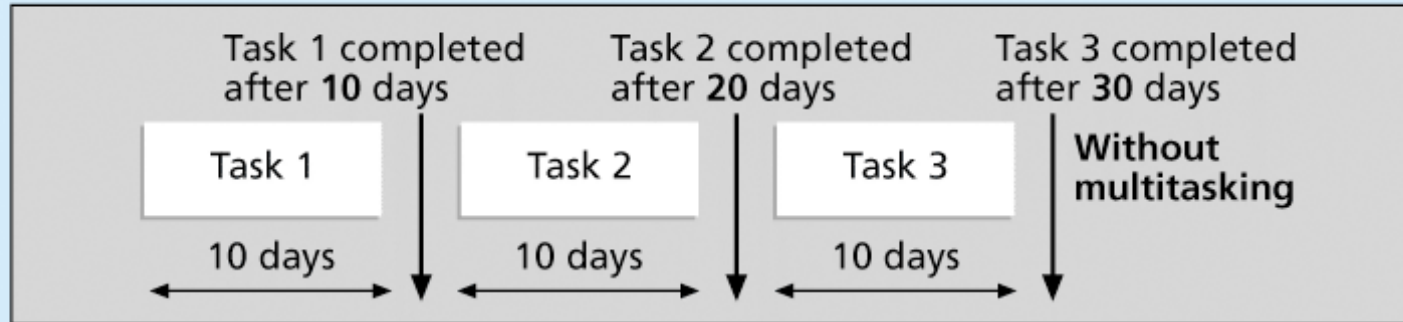

Buffers and Critical Chain

- ▶ A **buffer** is additional time to complete a task
- ▶ **Murphy's Law** states that if something can go wrong, it will
- ▶ **Parkinson's Law** states that work expands to fill the time allowed
- ▶ In traditional estimates, people often add a buffer to each task and use it if it's needed or not
- ▶ Critical chain scheduling removes buffers from individual tasks and instead creates
 - a **project buffer** or additional time added before the project's due date
 - **feeding buffers** or additional time added before tasks on the critical path

Example of Critical Chain Scheduling

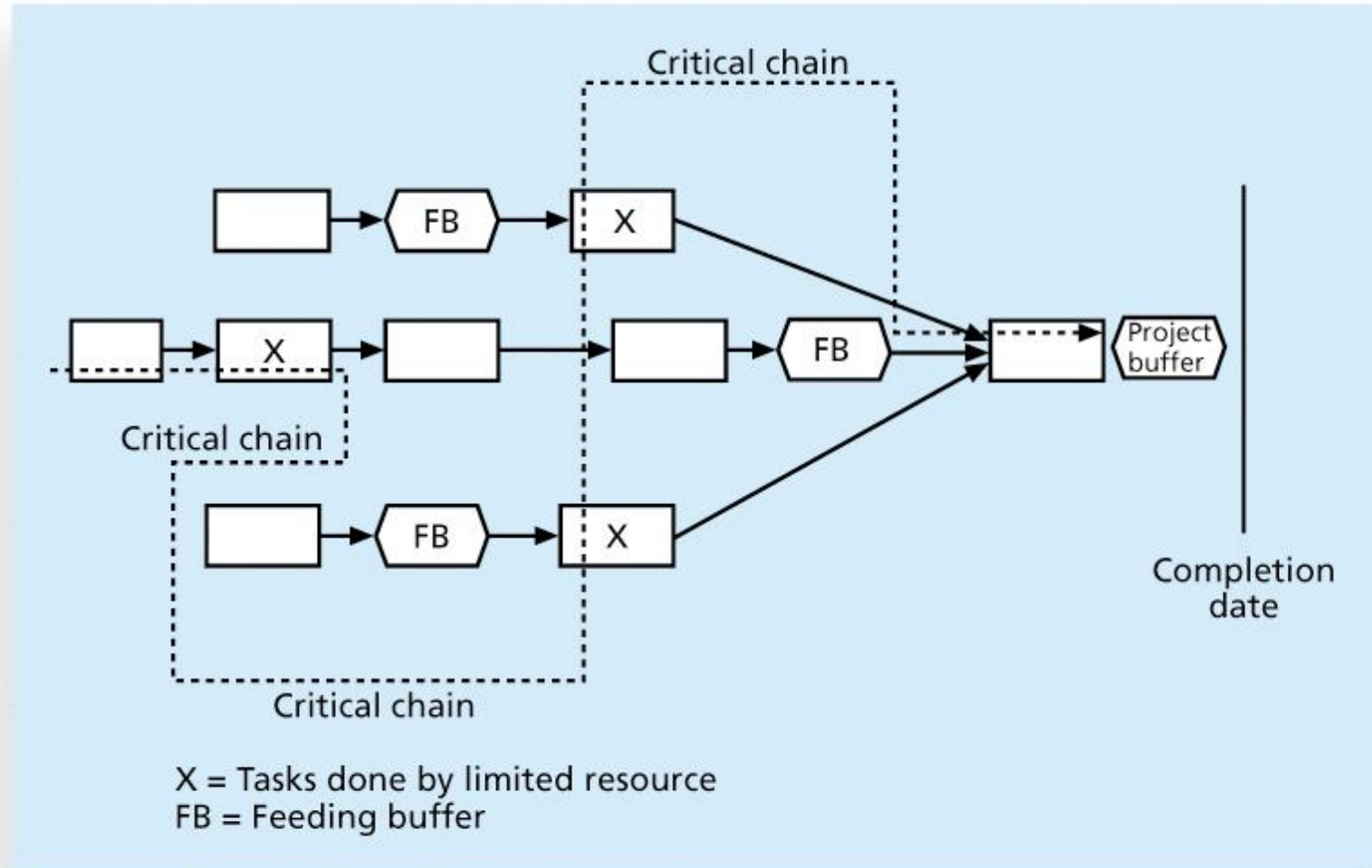

What Went Right?

- ▶ Scheduling at healthcare clinic's can be more efficient by using critical chain scheduling
- ▶ The National University Hospital in Singapore decreased patient admission times by more than 50 percent
- ▶ See www.goldratt.com for more information

Program Evaluation and Review Technique (PERT)

- ▶ **PERT** is a network analysis technique used to estimate project duration when there is a high degree of uncertainty about the individual activity duration estimates
- ▶ PERT uses **probabilistic time estimates**
 - duration estimates based on using optimistic, most likely, and pessimistic estimates of activity durations, or a three-point estimate

PERT Formula and Example

▶ PERT weighted average =
$$\frac{\text{optimistic time} + 4 \times \text{most likely time} + \text{pessimistic time}}{6}$$

▶ Example:

PERT weighted average =
$$\frac{8 \text{ workdays} + 4 \times 10 \text{ workdays} + 24 \text{ workdays}}{6} = 12$$

days

where optimistic time = 8 days

most likely time = **10 days**, and

pessimistic time = 24 days

Therefore, you'd use **12 days** on the network diagram instead of 10 when using PERT for the above example

Agile and Time Management

- ▶ Core values of the Manifesto for Agile Software Development are
 - Customer collaboration over contract negotiation
 - Responding to change over following a plan
- ▶ The product owner defines and prioritizes the work to be done within a sprint, so collaboration and time management are designed into the process
- ▶ Teams focus on producing a useful product in a specified timeframe with strong customer input
- ▶ Don't emphasize defining all the work before scheduling it

Schedule Control Suggestions

- ▶ Perform reality checks on schedules
- ▶ Allow for contingencies
- ▶ Don't plan for everyone to work at 100% capacity all the time
- ▶ Hold progress meetings with stakeholders and be clear and honest in communicating schedule issues

Controlling the Schedule

- ▶ Goals are to know the status of the schedule, influence factors that cause schedule changes, determine that the schedule has changed, and manage changes when they occur
- ▶ Tools and techniques include
 - Progress reports
 - A schedule change control system
 - Project management software, including schedule comparison charts like the tracking Gantt chart
 - Variance analysis, such as analyzing float or slack
 - Performance management, such as earned value

Reality Checks on Scheduling

- ▶ First review the draft schedule or estimated completion date in the project charter
- ▶ Prepare a more detailed schedule with the project team
- ▶ Make sure the schedule is realistic and followed
- ▶ Alert top management well in advance if there are schedule problems

Working with People Issues

- ▶ Strong leadership helps projects succeed more than good PERT charts
- ▶ Project managers should use
 - empowerment
 - incentives
 - discipline
 - negotiation

Using Software to Assist in Time Management

- ▶ Software for facilitating communications helps people exchange schedule-related information
- ▶ Decision support models help analyze trade-offs that can be made
- ▶ Project management software can help in various time management areas

Global Issues

- ▶ Microsoft tell the customer story of Mexico's Secretary of Economy, who wanted to ensure that IT initiatives aligned with business goals and improved project management efficiency
- ▶ After implementing new software, their IT team could handle four times the number of concurrent projects without adding more staff

Words of Caution on Using Project Management Software

- ▶ Many people misuse project management software because they don't understand important concepts and have not had training
- ▶ You must enter dependencies to have dates adjust automatically and to determine the critical path
- ▶ You must enter actual schedule information to compare planned and actual progress

Summary

- ▶ Project time management is often cited as the main source of conflict on projects, and most IT projects exceed time estimates
- ▶ Main processes include
 - Plan schedule management
 - Define activities
 - Sequence activities
 - Estimate activity resources
 - Estimate activity durations
 - Develop schedule
 - Control schedule